



**På vej fra middelmådighed
til superliga hos
PRODAN A/S
i Randers**



Prodan A/S...

- er en underleverandørvirksomhed inden for udvikling og bearbejdning af emner og konstruktioner i metal og plast.





Ejerkreds

Freddi Jensen
Per Hastrup
Jens Devantier
Jørgen Dam Nielsen
Lars Smidt Laursen





Historie

-
- 2007 Prodan A/S - fusion
 - 2005 Prodan Gears
 - 1999 Gigastaal
 - 1993 FJ Teknik
 - 1985 Dan-plast
 - 1962 Værum Smede- & Maskinværsted



Nyt domicil

Byggegrund: 44.712 m²

Brutto etageareal: 15.320 m²





Kompetencer

- Totalleverandør
- Netværk
- Udvikling

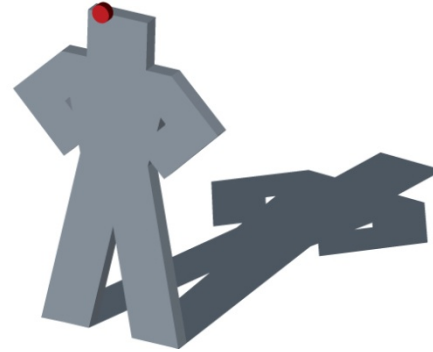

Klippe, bukke,
valse og svejse

Laser-, plastma-
og flammeskæring

Konstruktion,
udvikling og
opmåling

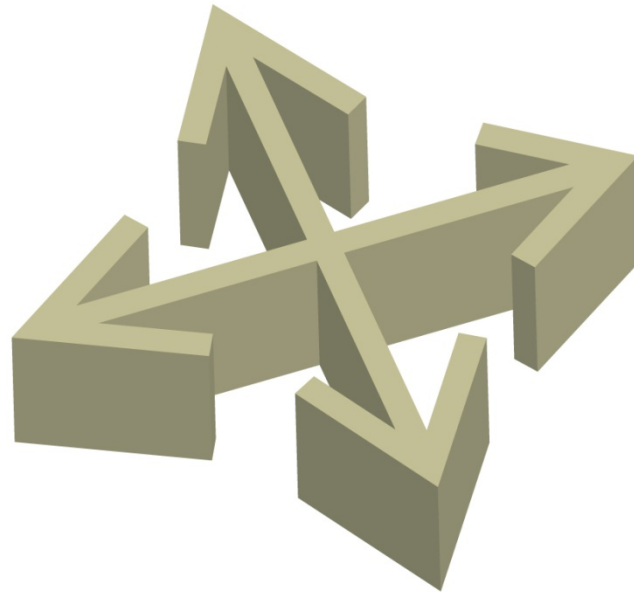

Fræse, dreje,
høvle og slibe



PLANTEGNING

Produktionsområde på ca. 14.500 m²
 Løftekapacitet: 20.000 kg





Manpower

130 medarbejdere

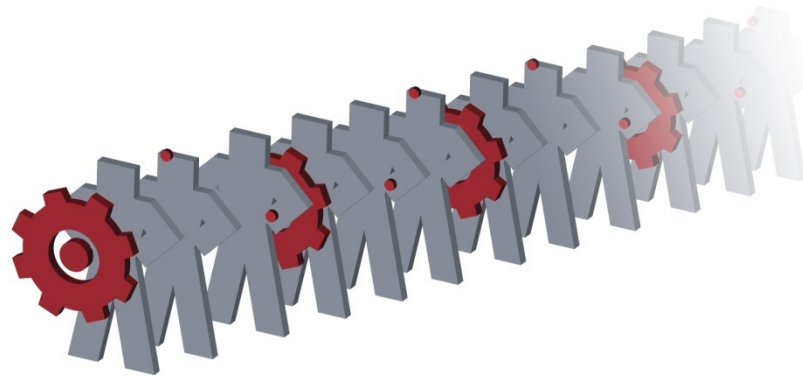



Kompetencer

- Totalleverandør
- Netværk
- Udvikling

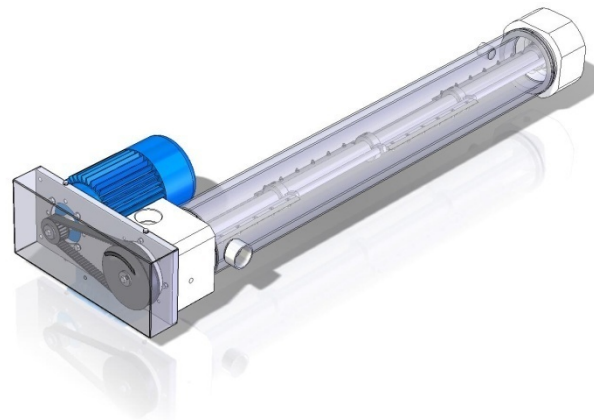
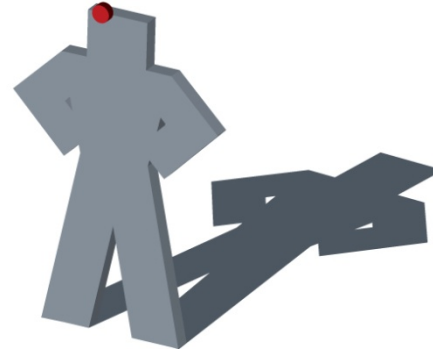



Teknologi

Dataudveksling
Bearbejdning
Kvalitet

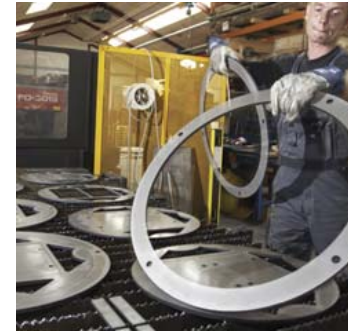
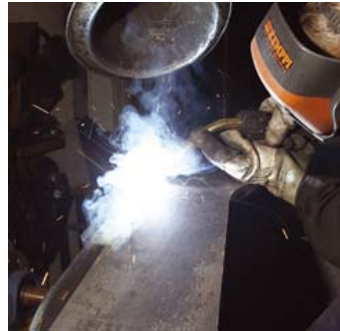



Bearbejdning



- 20 fræsere
- 24 drejebænke
- 20 pladebearbejdningsmaskiner



Kvalitet

4000 måleværktøjer

3D koordinatmålemaskine (1200x3000x1000mm)





Svejsning

- **Ca. 25 MIG – MAG strømkilder 160 – 400 amp.**
- **Ca. 10 TIG strømkilder AC/DC 160 – 300 amp.**
- **1 MOTOMAN svejserobot med FRONIUS strømkilde 500 amp.**
- **1 CLOOS svejserobot med CLOOS strømkilde 500 amp.**
- **Div. rundbordsautomater**



Svejeværksted for de blanke metaller





Svejeværksted for de blanke metaller





Svejeværksted for konstruktionsstål





Svejeværksted for konstruktionsstål





Svejeværksted for konstruktionsstål





Laserskæring





Kantpressere og maskinsaks





MOTOMAN svejserobot





CLOOS svejserobot





Nyt bearbejdningscenter

Rundbord: emner der er $\varnothing 5500 \times 3500$ mm

Firkantplan: emner der er $7000 \times 3000 \times 3500$ mm





Kærneværdier

- **Nærhed** Have tid til at lytte og udvise social omsorg
- **Ærlighed** Sige tingene uden omsvøb
- **Tryghed** Sikre dynamik og skabe tryghed i ansættelsen
- **Synlighed** Synlig ledelse gennem kommunikation og handling
- **Kvalitet** Kunden kommer tilbage – ikke emnet
- **Stolthed** Opnås først når værdierne efterleves til gensidig glæde for alle ansatte hos Prodan



Kulturændring

- Fra middelmådighed til superliga
 - Kan kræve holdningsændring
 - Kræver fleksibilitet
 - Har faglige kvalifikationer
 - Besidder faglig stolthed
 - Er kvalitetsbevidst
 - Er en god kollega
 - Man er på fra start til slut



Kunde / myndighedskrav

- ISO 9001 certificeret
- Vindmølleindustrien
- Norske off-shore
- Myndighederne



Kvalitetstyringsmål

- Senest 30. juni 2010 er virksomheden
ISO 9001 certificeret
- Inden 31. december 2009 er virksomheden
auditeret iht. **DS/EN ISO 3834-3 (2)**
- Inden 31. december 2009 skal virksomheden
leve op til
DS/EN 1090 EXC 2 (3) og CC2 (3)



Kvalitet implementering

- Dokumentstyring
 - WPQR
 - WPS
 - Materialecertifikater
 - Tilsatsmaterialer
 - Personale kvalifikationer
 - Kalibrering af måleudstyr
 - Service og kalibrering af svejsemaskiner
 - NDT rapportering
 - Ekstern personale kvalifikationer
 - Afvigelsesrapportering