

SECTION A-A  
SCALE 1 : 1

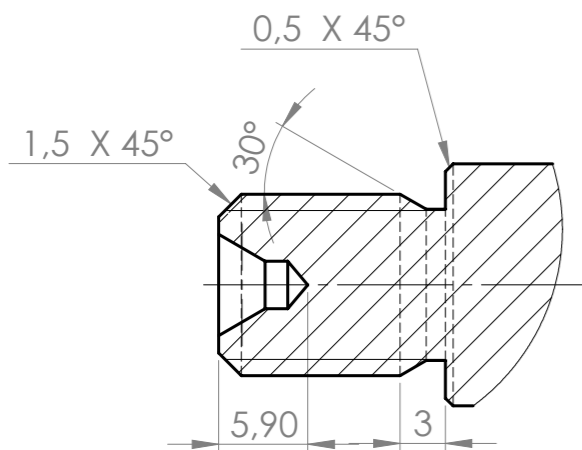
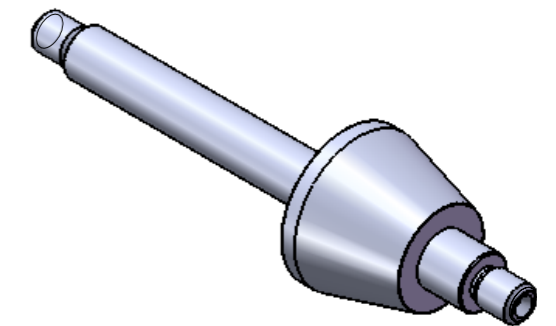

DETAIL B  
SCALE 2 : 1  
Ens i begge ender

Individuel svendeprøve	REVISION 1
Alle mål uden tolerancer efter DS: 2768-1 f Alle kanter rejfes 1 X 45°	
Navn:	
Dreje opgave 9	
Råemne:	Materiale:
Ø60 x 185	Stål 52